

VS 160s

Vacuum Soldering Systems

budatec®

Equipment for semiconductor and photovoltaic industries

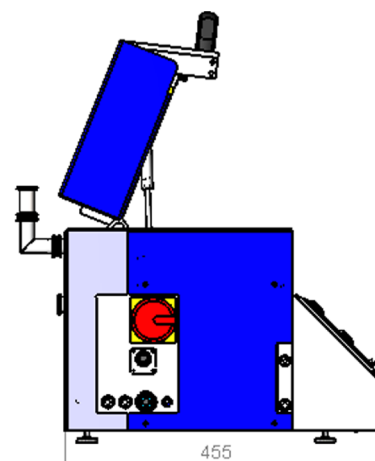
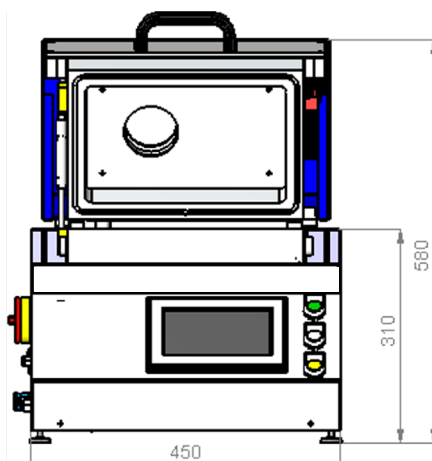

Technical Data:	plate size:	160mm x 160mm
	max. substrate height:	50mm
	max. solder temperature:	450°C
	heat up / cool down:	max. 3K/s
	max. load:	2,5kg
	possible process gases:	N2; N2H2 95/5%
	power supply:	400V /16A
	cooling water:	10slm
	weight:	~ 50kg

Options: absolute pressure measurement
rotary vane pump with accessories

Made in Germany

budatec
www.budatec.de

info@budatec.de

08/2013 reserve modifications;

budatec GmbH, Segelfliegerdamm 92, 12487 Berlin
Tel. +49-30-63224070 Fax+49-03 -63224071